

Moline Vertical Stamping Unit



A versatile and efficient cutting system designed to cut elaborate product shapes while minimizing scrap.

Shown in shutdown mode with infeed guard raised to expose stamping die.



- ***Accommodates conveyor widths of 24" to 60".***
- ***Stamping dies can be easily changed to vary product shapes.***
- ***Operator interface provides an easy-to-use touch screen for operating adjustments.***
- ***Maximum Cycle Rate: Call Moline Engineering for details.***

The Moline vertical stamping unit has been installed in progressive, high-volume bakeries throughout the industry, providing durable and efficient production. The unit is designed to cut various product shapes out of the dough sheet using a stamping die. The "walking" action of the stamper allows the product to be cut as the dough sheet moves through the machine on a conveyor. Production rates are high with very little scrap generated due to the "nested" layout of the stamping die cutters.

The stamping die is easily interchangeable to vary product shapes as needed. The dough is stripped from the cutters when they retract, thus creating the stamped product. Cutting depth, stamping speed and cut length are easily adjustable.

The operator interface provides an easy-to-use touch screen for stamper adjustments.



Moline Machinery LLC

114 South Central Avenue • Duluth, Minnesota, USA, 55807
218-624-5734 (For after hours service, call 218-590-1987)
www.moline.com • sales@moline.com



Moline Vertical Stamping Unit

Stamper Features

- **Construction:**
Heavy-gauge stainless steel construction. Precision machined components.
- **Guards and Covers:**
Safety interlocked guards prevent access to the die during operation. Doors on both ends of the stamper provide access to the pneumatics, flywheel area and linkage.
- **Control Functions:**
Walking plate speed is easily adjusted with the control knob located on the stamper cabinet. Other adjustments are accessed via the operator interface.
- **Drive System:**
Servo or variable frequency drive systems are available depending on product requirements.



Vertical Stamping Unit

Stamping Die

- **Cutting Pattern Layout and Width**
The stamping die cutting pattern layout and width vary depending upon customer specifications.
- **Cutting Depth**
Cutting depth adjustment fasteners allow easy depth adjustment per product specifications.
- **Easily Interchangeable**
The die is easily interchangeable to vary product shapes.

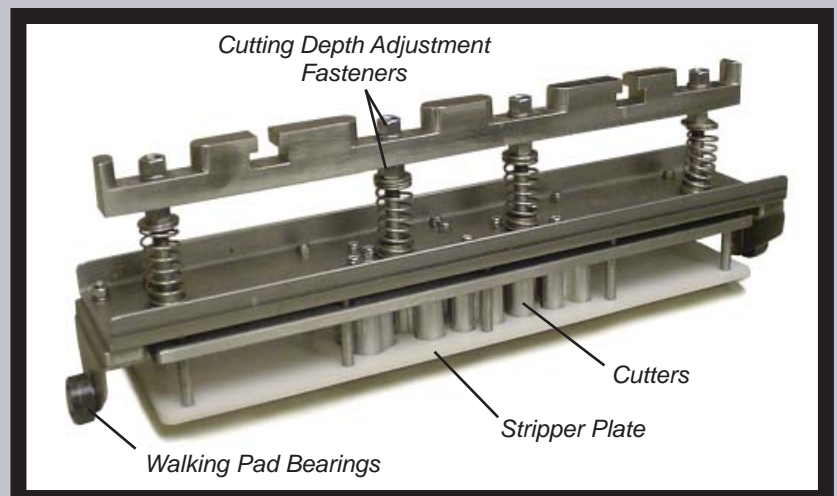

Typical Stamping Die